



Kahramanmaraş Sütçü İmam University

Journal of Engineering Sciences



Geliş Tarihi : 15.05.2023
Kabul Tarihi : 04.01.2024

Received Date : 15.05.2023
Accepted Date : 04.01.2024

PERFORMANCE ANALYSIS OF OPTICAL WIRELESS COMMUNICATION SYSTEM DESIGNED BY USING DIFFERENT FILTERS

FARKLI FİLTRELER KULLANILARAK TASARLANAN OPTİK KABLOSUZ HABERLEŞME SİSTEMİNİN PERFORMANS ANALİZİ

Fethiye Merve KAVAK İMAK^{1*} (ORCID: 0000-0001-6180-8263)
Duygu KAYA² (ORCID: 0000-0002-6453-631X)

^{1,2}Firat University, Faculty of Engineering, Electrical-Electronics Engineering, Elazığ/ Turkey

Corresponding Author: Fethiye Merve KAVAK İMAK, kavakmervef@gmail.com

ABSTRACT

Free space optical communication (FSO) technology, which has been developing in recent years, is advantageous compared to other wireless communication technologies due to its features such as high bandwidth, low latency, and high security. Since the FSO system is sensitive to atmospheric events, it needs various signal processing and filtering techniques to reduce the deterioration in the quality of the signal. The FSO free space channel has several channel types, such as the scattered channel and the optical wireless communication (OWC) channel. In this study, comparisons were made using various filters in an FSO system designed using the optical wireless communication (OWC) transmission channel model, and the system was analyzed based on the results obtained.

Keywords: Optical wireless communication (OWC), free space optical communication (FSO), bit error rate (BER), Q factor, optical filter

ÖZET

Son yıllarda gelişmekte olan serbest uzay optik iletişim (FSO) teknolojisi, yüksek bant genişliği, düşük gecikme süresi ve yüksek güvenlik gibi özelliklerinden ötürü diğer kablosuz iletişim teknolojilerine kıyasla avantajlı durumdadır. FSO sistemi atmosferik olaylara karşı hassasiyet içerdiğinden sinyalin kalitesinde gerçekleşen bozulmaların azaltılması için çeşitli sinyal işleme ve filtreleme tekniklerine ihtiyaç duymaktadır. FSO boş alan kanalının dağınık kanal ve optik kablosuz iletişim (OWC) kanalı gibi çeşitli kanal türleri bulunmaktadır. Bu çalışmada optik kablosuz iletişim (OWC) iletim kanal modeli kullanılarak tasarlanan bir FSO sisteminde çeşitli filtreler kullanılarak karşılaştırmalar yapılmış ve elde edilen sonuçlar üzerinden sistem analiz edilmiştir.

Anahtar Kelimeler: Optik kablosuz iletişim (OWC), serbest uzay optik iletişimi (FSO), bit hata oranı (BER), Q faktörü, optik filtre

INTRODUCTION

Free space optical technology (FSO) is an optical communication system that transmits high-bandwidth data. However, since the data transmission channel is atmosphere, system performance is directly dependent on atmospheric conditions. Therefore, researchers have been working to improve the performance of FSO systems (Bayraktar, 2020). Optical wireless communication (OWC) is a communication technology that uses a line of sight to transmit signals, data, and information between two points. OWC relies solely on optical communication and uses a free space-spreading transmission medium as the transmission line. In this context, Optical wireless communication (OWC) is a technology that includes free field optical communication (FSO). OWC technology is used when physical connection is not possible (Yadav Kumar et al., 2014). The transmission environments determine the difference between an OWC system and an FSO system. OWC system is also a line-of-sight based communication technology like free field optics (FSO), but it is based on optical communication only and uses air as the transmission medium. FSO, on the other hand, can use a transmission line such as an optical fiber cable or optical as the transmission medium. These differences arising from different transmission environments can cause differences in performance and efficiency between OWC and FSO (Goyal et al., 2015).

Many studies have been carried out recently to analyze the performance of OWC systems. In his study on OWC, Shabaneh made a system performance analysis by comparing the systems established with APD and PIN photodetectors (Shabaneh, et al.). The study of Mohsen and his friends with the OWC system was based on the investigation and comparison of various parameters in OWC systems designed with RZ and NRZ coding techniques (Dehaq E. Mohsen, 2023). El-Mokadem and his colleagues examined the effects of various weather conditions on OWC systems and made performance analysis with various designs (El-Mokadem et al., 2023).

When transmitting signals in an OWC system, a PRBS generator is used to convert analog signals to digital format, and an external modulation is used for optical modulation. It is carried out using a CW laser array consisting of four different laser signal wavelengths around the wavelength of 1550 nm and the frequency range of 100 GHz. These laser signals are combined with WDM technology and form a CW laser with the same frequency and frequency range. The digitized signal is modulated with the help of the multiplexed laser signal and transmission is provided by OWC (Tiwari et al., 2015). The low-pass filter used in the system is a type of filter used to suppress high-frequency components and pass low-frequency components. This filter performs signal processing using the frequency transfer function (Uzun, 2019). The block diagram of the OWC system is shown in Figure 1.

Visible Light Communication has an advantage over other communication branches in terms of energy efficiency, high bandwidth and reliability. In this study, an Optical Wireless Communication (OWC) system was designed using 5 different filters in order to analyze the performance of systems in which data transmission is provided by visible light communication. The main contributions of the study are:

- In transmissions carried out with the OWC channel type, whose working principle is based on optical signal transmission in a free air environment, the elements used in the system were examined in order to minimize the negative effects caused by the environment.
- In the OWC systems established in the study, the best transmission was tried to be achieved by using different parameters.
- The results obtained from the designed systems have shown that the transmission quality can be improved with alternative systems established with different parameters and elements.

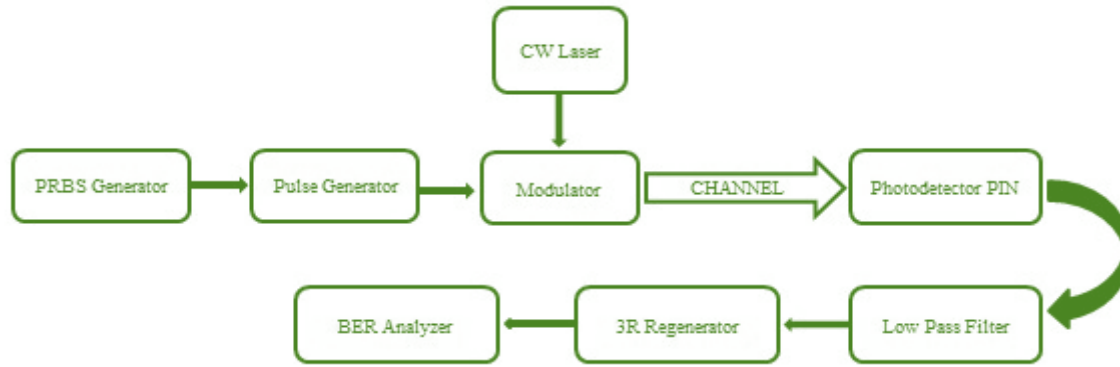

Figure 1. Block Diagram of an OWC System

FILTER USAGE IN OPTICAL WIRELESS COMMUNICATION SYSTEM

In communication systems, two port structures used to provide a certain frequency response are defined as filters (Arslan, 2020). Optical filters are optical elements that allow selective transmission or blocking of beams of particular wavelengths. These filters are used in different types of optical networks and devices, changing the transmission characteristics. There are various types of optical filters, they can be produced using semiconductor technology as well as other optical materials can be used. These filters can be used in wavelength division multiplexing (WDM) systems, optical fiber communication systems, optical sensors, lasers, optical spectroscopy, and optical microchips.

Low pass optical filters are one of the filter technologies used in optical systems. These filters function as selective filtering by blocking signals of higher wavelengths or frequencies while passing signals below a certain wavelength or frequency. For example, a low-pass optical filter can pass light signals below a certain wavelength or frequency, while blocking light signals above it. In this way, the frequency spectrum of the filtered optical signal is lowered and its amplitude is reduced, reducing the sharpness of the signal and smoothing it. Low-pass optical filters can be used in many optical applications such as color correction, camera lenses, cameras, optical sensors, and analyzers. These filters allow the filtering of unwanted signals without changing the characteristics of the optical signal.

OWC SYSTEM DESIGN WITH DIFFERENT FILTER TYPES

The Optisystem simulation program was used to analyze the performance of filter types in the OWC system. The system basically consists of a transmitter, receiver, and OWC channel. The transmitter part is designed so that the receiver can communicate wirelessly. The input signal is fed from a pulse generator. The CW laser used in the system is responsible for transmitting the signal away. The signal to be transmitted is modulated with the Mach Zehnder modulator, which is known to work with high performance in the wireless communication system. The receiver consists of a photodiode that receives the laser signals transmitted from the OWC channel and a filter that reduces the noise in the signal and increases the signal quality. A BER analyzer was used to analyze the designed system. The CW laser power used in the system is selected as 20 dBm and the laser operates at a wavelength of 550 nm. The receiver and transmitter aperture diameter of the OWC channel is 30 cm, and the OWC channel lengths used for analysis in the system are 100, 200, 300, 400, and 500 m, respectively.

In the literature, IIR digital filters are generally used in studies on OWC systems. In the study, low-pass IIR digital filter types such as low-pass Gaussian filter, low pass Bessel filter, low pass Butterworth filter, low pass Chebyshev filter, and low pass Raised Cosine filter are used to filter the signal obtained from the photodiode output.

Figures 2,3,4,5 and 6 show OWC systems with low pass Gaussian filter, low pass Bessel filter, low pass Butterworth filter, low pass Chebyshev filter, and low pass Raised Cosine filter, respectively.

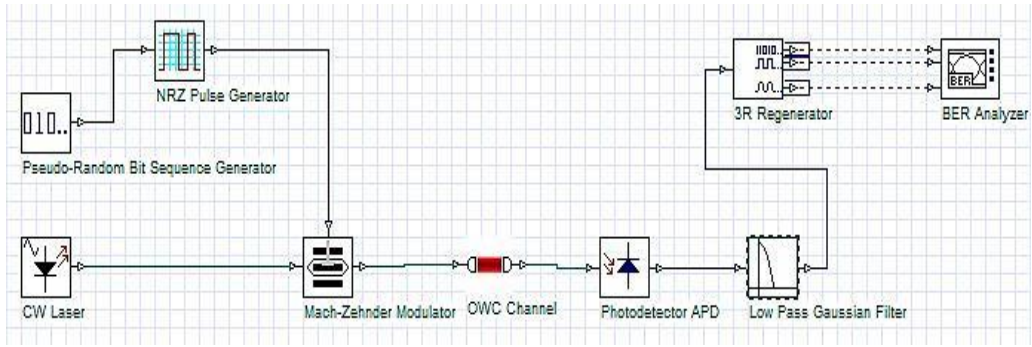

Figure 2. OWC System Designed with Low Pass Gaussian Filter

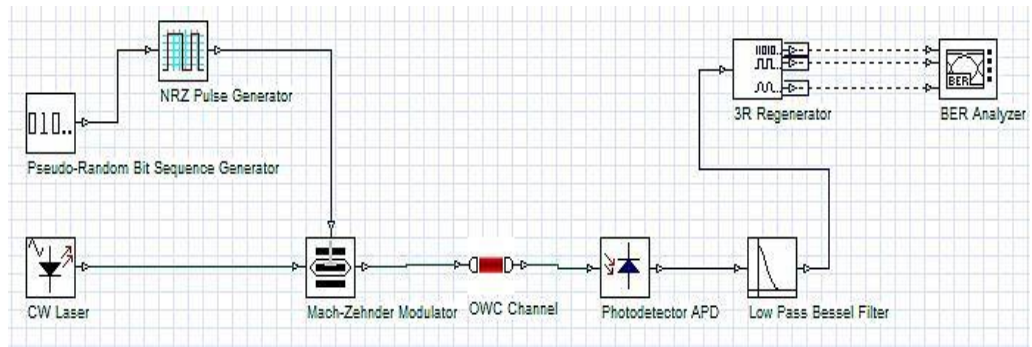

Figure 3. OWC System Designed with Low Pass Bessel Filter

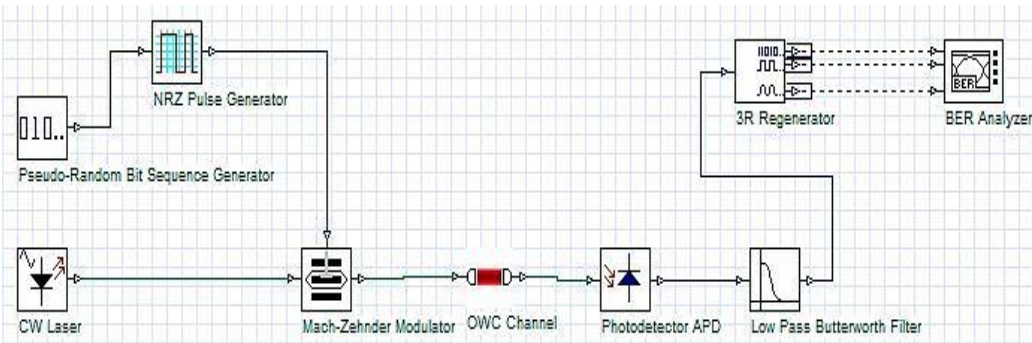

Figure 4. OWC System Designed with Low Pass Butterworth Filter

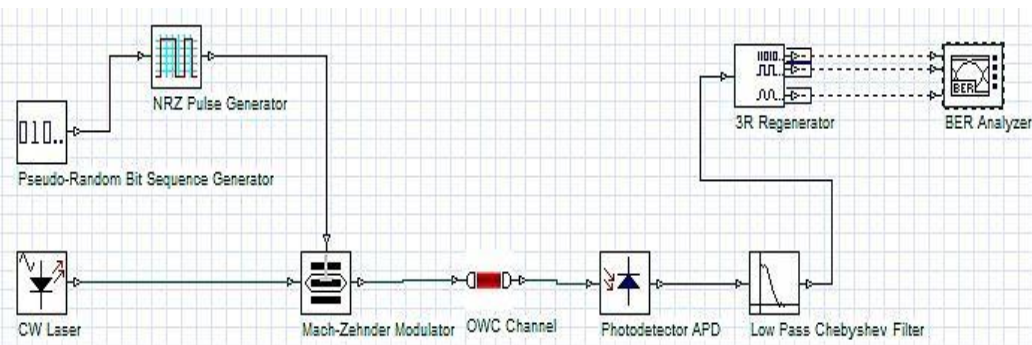

Figure 5. OWC System Designed with Low Pass Chebyshev Filter

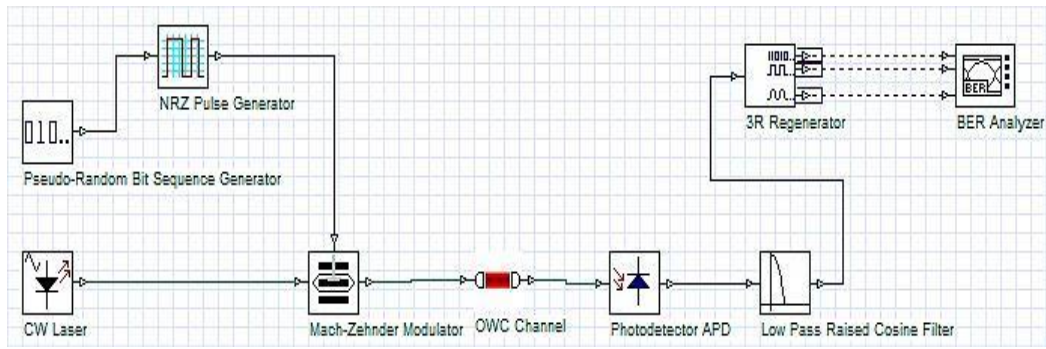

Figure 6. OWC System Designed with Low Pass Raised Cosine Filter

OWC SYSTEM ANALYSIS

BER Analyzer

In this section, the systems simulated using the BER analyzer with the communication system simulation program called Optisystem are examined. With the BER analyzer, eye diagrams were obtained to show the quality of the system. The aperture ratio in the eye diagrams shows the good working performance of the system. BER reveals the percentage of incorrect bits relative to the total number of bits of a received signal (Shivam et al., 2023). The eye diagrams obtained from the BER analyzer of the OWC system designed with low pass Gaussian, Bessel, Butterworth, Chebyshev, and Raised Cosine filters are shown in Figures 7, 8, 9, 10, and 11, respectively.

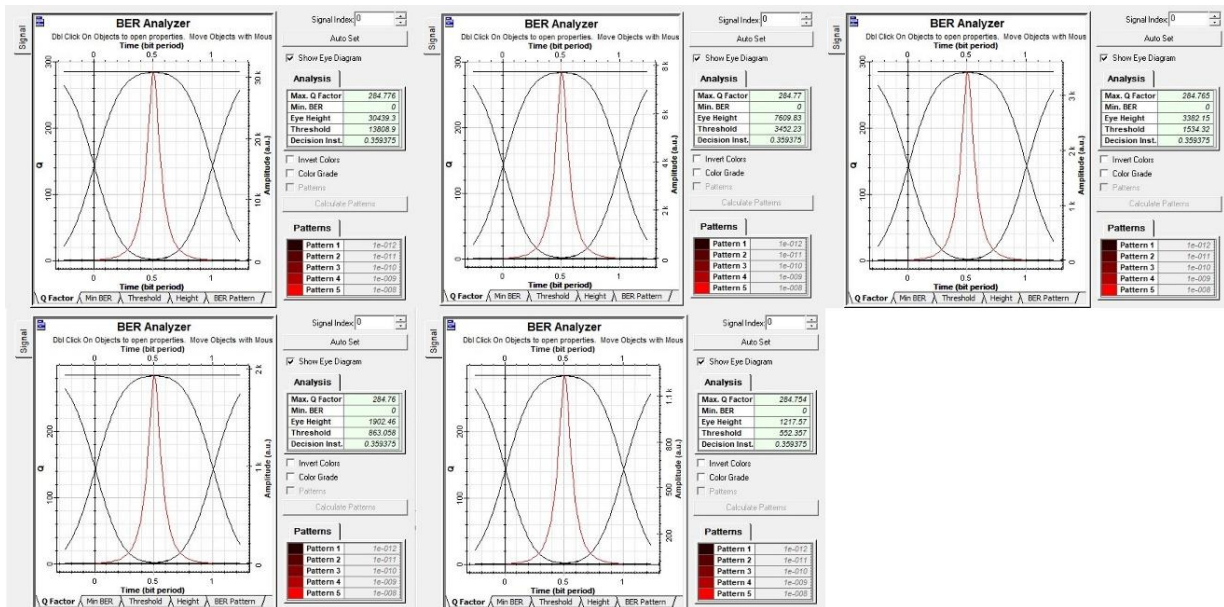

Figure 7: Eye Diagram Outputs of The OWC System Installed with A Low Pass Gaussian Filter for $V=100,200,300,400,500$ m

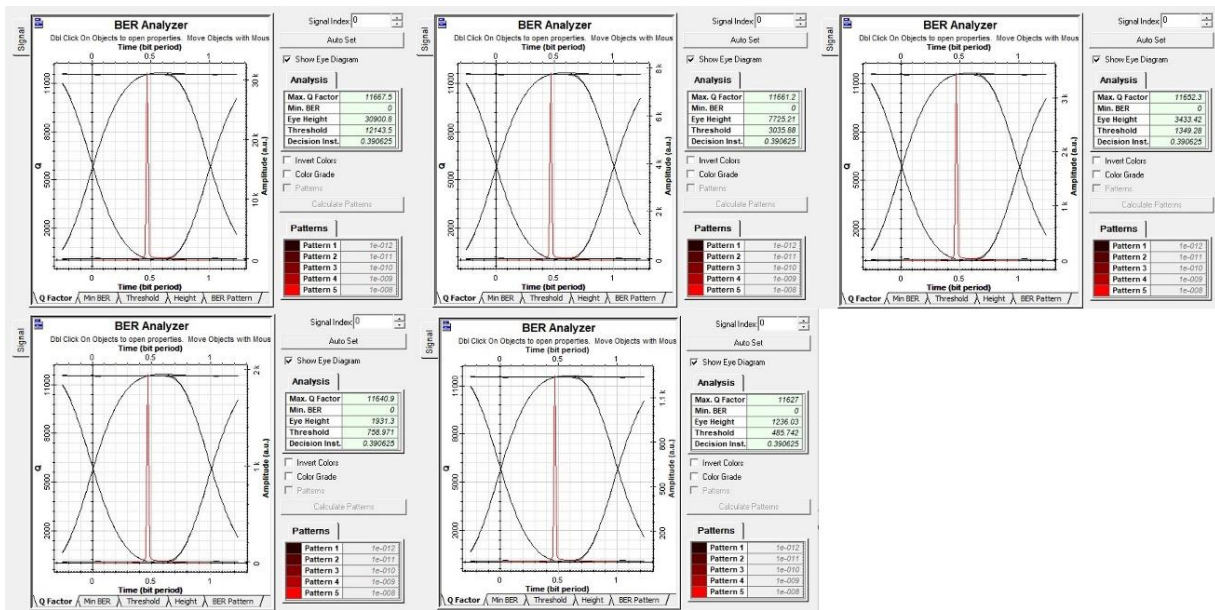

Figure 8: Eye Diagram Outputs of The OWC System Installed with Low Pass Bessel Filter for $V=100,200,300,400,500$ m

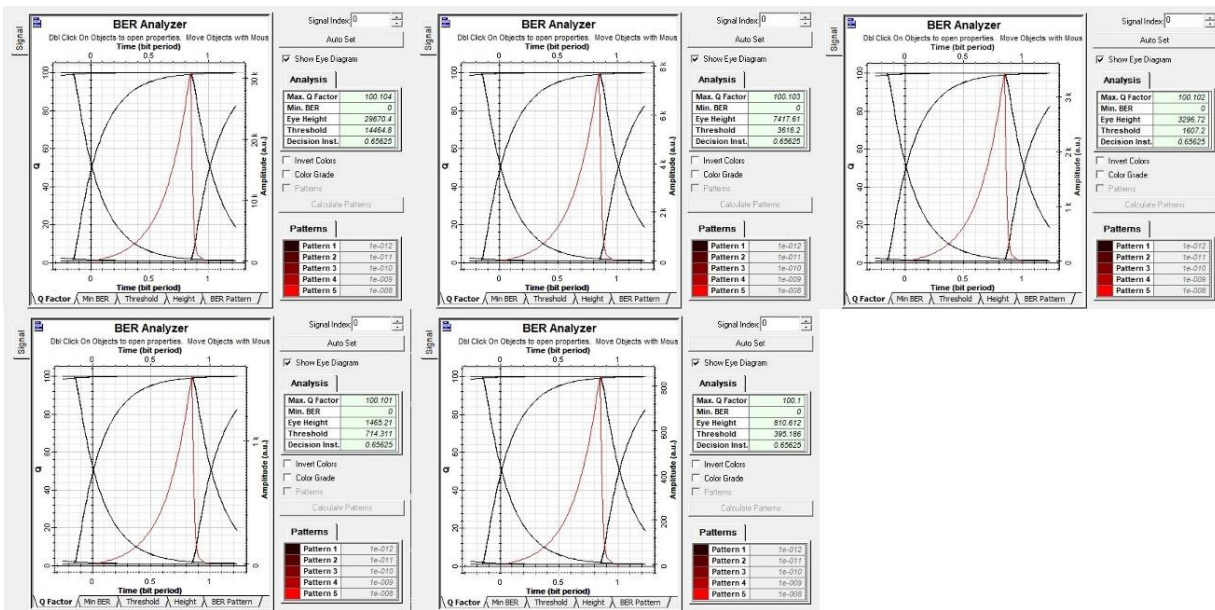

Figure 9: Eye Diagram Outputs of The OWC System Installed with Low Pass Butterworth Filter for $V=100,200,300,400,500$ m

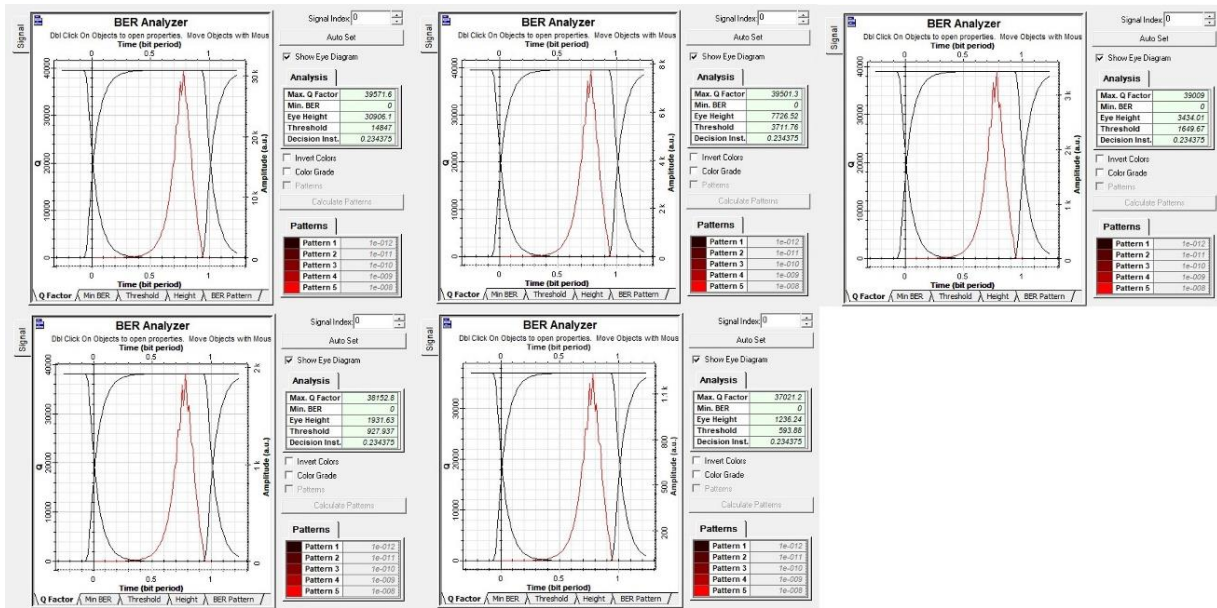

Figure 10: Eye Diagram Outputs of The OWC System Installed with Low Pass Chebyshev Filter for $V=100,200,300,400,500$ m

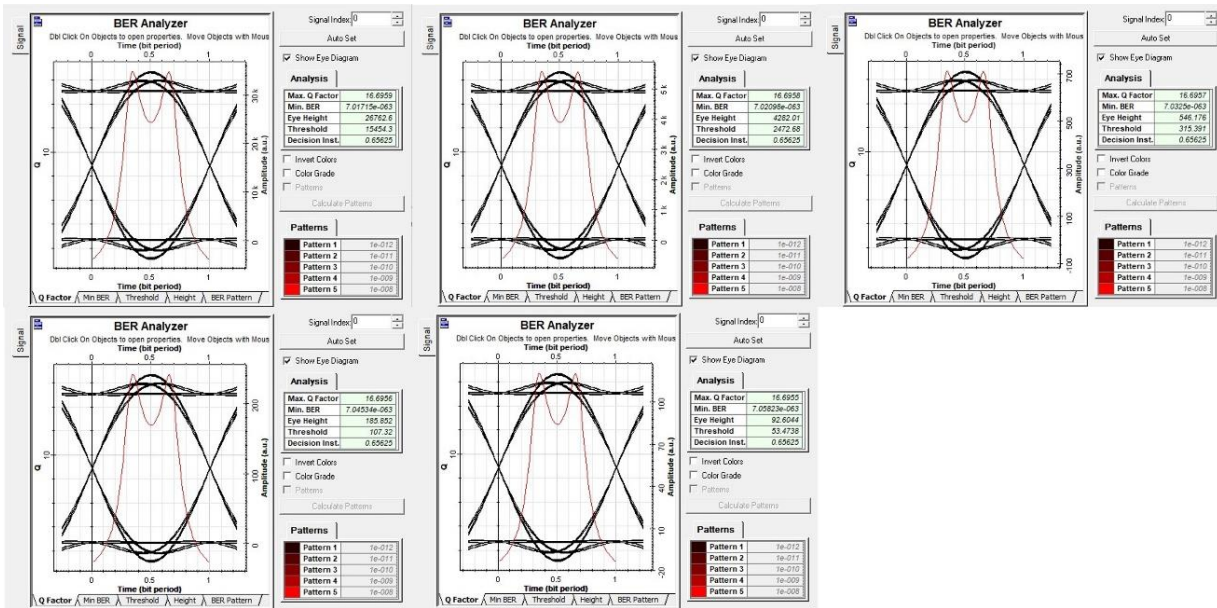

Figure 11: Eye Diagram Outputs of The OWC System Installed with Low Pass Raised Cosine Filter for $V=100,200,300,400,500$ m

Max. Q Factor Analysis

In wireless communication systems, the Max Q factor refers to the point where the signal strength is the most intense. Max Q factor is a parameter used to optimize signal strength in wireless communication systems. Especially when transferring data over long distances or at high speeds, detecting and focusing on the point where the signal is most intense helps to prevent data loss. Therefore, Max Q factor analysis is an important tool to improve the performance of wireless communication systems. Table 1 shows the Max Q factor values that vary depending on the channel length.

Table 1: Max Q Factor Values Based on OWC Channel Length

		Channel length				
		100 m	200 m	300 m	400 m	500 m
Max Q factor	LP Bessel Filter	11667.5	11661.2	11652.3	11640.9	11627
	LP Gaussian Filter	284.776	284.77	284.765	284.76	284.754
	LP Butterworth Filter	100.104	100.103	100.102	100.101	100.100
	LP Chebyshev Filter	39571.6	39501.3	39009	38152.8	37021.2
	LP Raised Cosine Filter	16.6959	16.6958	16.6957	16.6956	16.6955

Eye Height Analysis and Min. BER Analysis

In wireless communication systems, various factors affect the transmitted signal quality. One of them is eye height. The transmitted signal consists of data bits, which are at a certain level during the modulation of the signal. Eye height refers to the distance between the lowest and highest points of these signal levels and is used as an indicator of signal quality. In Table 2, the Eye Height values, which vary depending on the length of the channel, are shown.

Min BER analysis expresses the minimum error rate of a communication system. Bit error rate is a measure of how many errors will be made during data transfer in a transmission system. Min BER refers to the level at which it can achieve the lowest error rate in a given signal quality. This value is important for measuring the performance of a transmission system. In Table 3, Min BER values that vary depending on the channel length are shown.

Table 2: Eye Height Values Based on OWC Channel Length

		Channel length				
		100 m	200 m	300 m	400 m	500 m
Eye Height	LP Bessel Filter	30900.8	7725.21	3433.42	1931.3	1236.03
	LP Gaussian Filter	30439.3	7609.83	3382.15	1902.46	1217.57
	LP Butterworth Filter	29670.4	7417.61	3296.72	1465.21	810.612
	LP Chebyshev Filter	30906.1	7726.52	3434.01	1931.63	1236.24
	LP Raised Cosine Filter	26762.6	4282.01	546.176	185.852	92.6044

Table 3: Min BER Values Based on OWC Channel Length

	Channel length				
	100 m	200 m	300 m	400 m	500 m
LP Bessel Filter	0	0	0	0	0
LP Gaussian Filter	0	0	0	0	0
LP Butterworth Filter	0	0	0	0	0
LP Chebyshev Filter	0	0	0	0	0
LP Raised Cosine Filter	7.01×10^{-63}	7.02×10^{-63}	7.03×10^{-63}	7.04×10^{-63}	7.05×10^{-63}

Choosing the laser power as 20 dBm in the system caused the effects of high attenuation in the free space environment to decrease, and the BER values of the system were close to zero.

Figure 12 shows the performance graph created by taking the Max Q factor values obtained from the system.

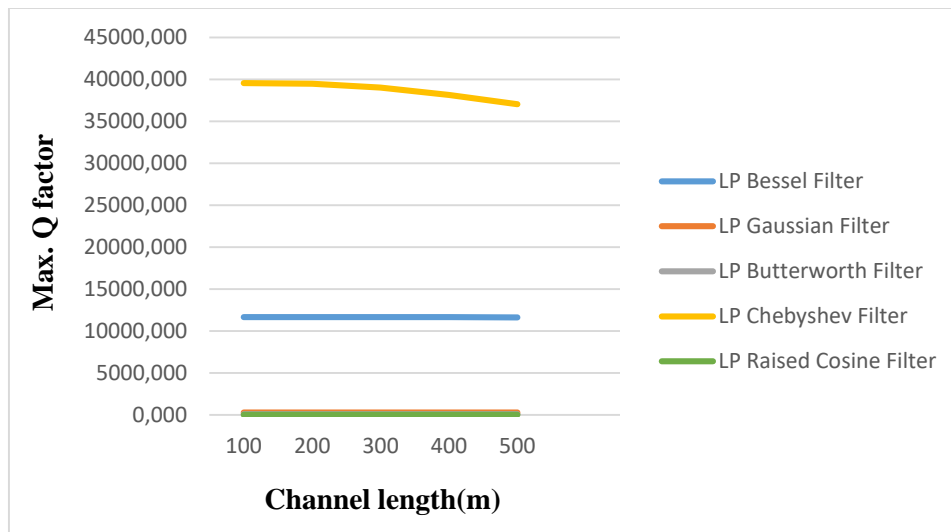

Figure 12: Performance Graph of the OWC System Designed with Low-Pass Gaussian, Bessel, Butterworth, Chebyshev and Raised Cosine Filters Based on the Change of Channel Length

CONCLUSION

In the study, an Optical Wireless Communication (OWC) system was designed using 5 different filters. First of all, the effect of channel length on the transmission system was examined in the study. As a result of the analysis, as the channel length increased in the OWC system, there was a decrease in the quality of the system. This decrease is clearly seen in the eye diagrams obtained from the Optisystem simulation program. As the channel length increases, the mesh size of the system decreases, which means that the transmission quality decreases. Then, by changing the channel length of OWC systems designed for low pass Gaussian filter, low pass Bessel filter, low pass Butterworth filter, low pass Chebyshev filter and low pass Raised Cosine filter, Max. Q factor, Min. BER analysis and eye height results were obtained. The results obtained from the installed OWC systems show that the low pass Bessel filter allows obtaining a better signal than other filter types.

THANKS

This study was supported by the Scientific Research Projects Coordination Unit of Firat University. Project number MF.24.01.

ACKNOWLEDGMENT

This study has been produced from the master thesis of Fethiye Merve KAVAK İMAK.

REFERENCES

- Arslan, E. (2020). *Mikroşerit alçak geçiren filtre tasarımı ve analizi* [Master's thesis]. Fen Bilimleri Enstitüsü.
- Bayraktar, M. (2020). Serbest Uzay Optik Haberleşme Sistemlerinde Turbo Çarpım Kodların Performans Analizi. *EMO Bilimsel Dergi*, 10(1), 45–48.
- Dehaq E. Mohsen, E. M. A. M. M. A. (2023). Performance Analysis of OWC System based (S-2-S) Connection with Different Modulation Encoding. *International Journal of Intelligent Systems and Applications in Engineering*, 11(4s), 400–408.
- El-Mokadem, E. S., Tawfik, N. I., Aly, M. H., & El-Deeb, W. S. (2023). *Design and performance evaluation of vehicular visible light communication system under different weather conditions and system parameters*. <https://doi.org/10.24425/opelre.2023.145580>
- Goyal, H., Saxena, J., & Dewra, S. (2015). Performance analysis of optical communication system using different channels. *Int J Adv Res Comput Commun Eng*, 4, 19–22.
- Shabaneh, A. A. A. (n.d.). (2022) Performance Analysis And Comparison Of Apd And Pin Photodetectors Using Optical Wireless Communication Channel. *International Journal of Electrical, Electronics and Data Communication*, 2022(10), 2321–2950.
- Shivam, Sharma, C., Singh, S., & Kumar, R. (2023). Performance Analysis of an Indoor Visible Light Communication System Using Optisystem Software. *2023 3rd International Conference on Advances in Electrical, Computing, Communication and Sustainable Technologies, ICAECT 2023*. <https://doi.org/10.1109/ICAECT57570.2023.10117680>
- Tiwari, P., Jaiswal, A. K., Agrawal, N., Professor, A., & Nitin, N. (2015). Analysis of Bidirectional Wireless Optical Channel Integrated with Optical Fiber. *International Journal of Computer Applications*, 121(5), 975–8887.
- Uzun, P. (2019). *Görünür ışık haberleşmesinde modülasyon türlerinin incelenmesi* [Master's thesis]. Fen Bilimleri Enstitüsü.
- Yadav Kumar, S., Professor, Y. A., & Chouhan, S. (2014). Performance Analysis of Optical Wireless Communication Link By Multiple Tx/Rx with and Without Amplifier. *International Journal of Engineering Research & Technology (IJERT)*, 3.